

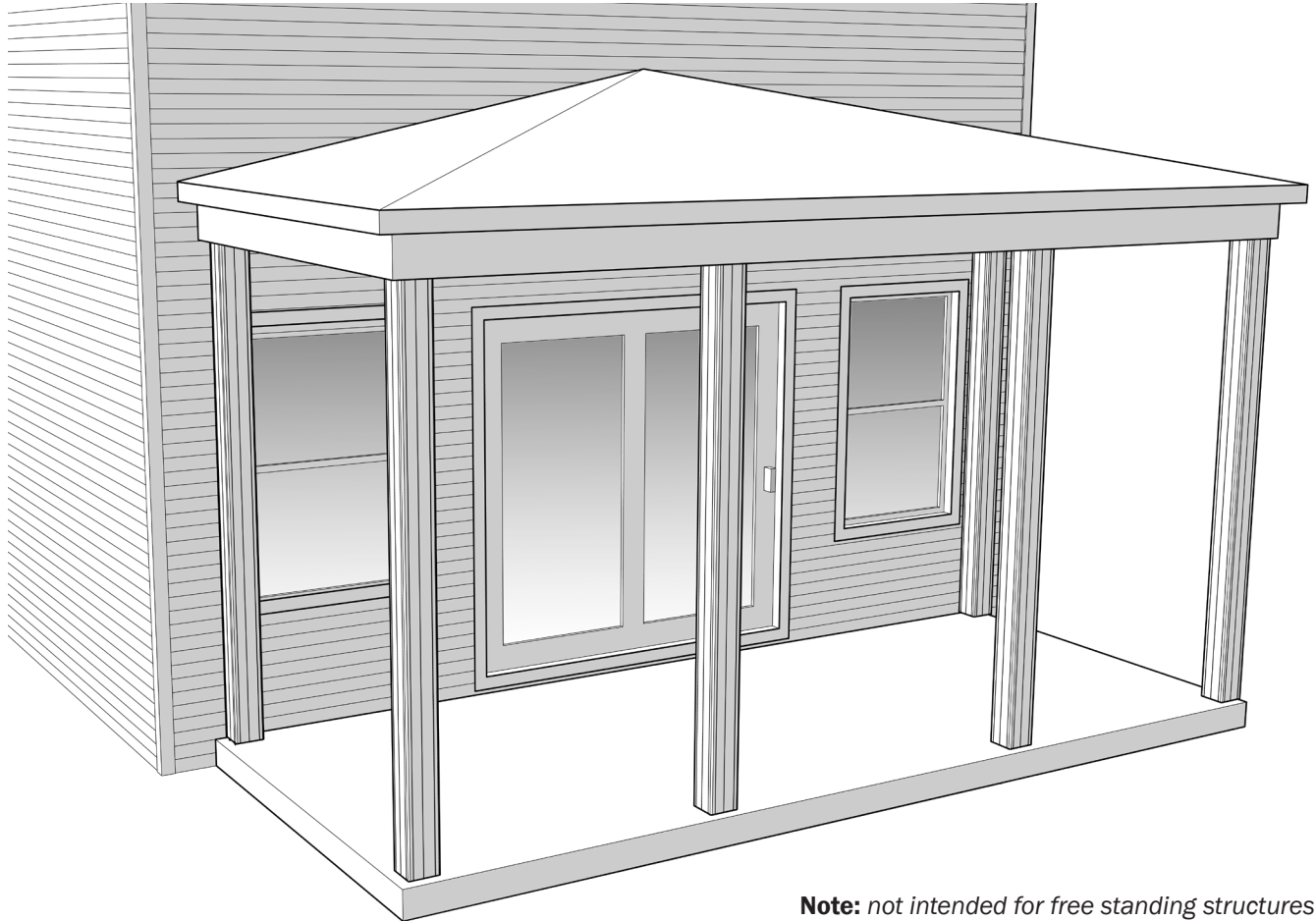

SUPERIOR[™]
PLASTIC PRODUCTS

Vinyl Post Wrap



Note: not intended for free standing structures

Recommended Tools

- Safety Glasses
- Tape Measure & Pencil
- Power Drill
- Circular Saw

What's Included (per Post)

- (4) Post Wrap Panels
- (2) Snap on Trim (optional)
- (8) Flat Head Screws

- *These directions are only a guide and may not address every situation.*
- *Always wear proper safety equipment while assembling and installing.*
- *The installer should obtain all required building permits and follow all installation procedures in accordance with applicable building code requirements.*
- *Superior Plastic Products, Inc. shall not be held liable for improper or unsafe installations.*
- *Applying paint, will void your warranty.*
- *To ensure proper coverage by our warranty please visit our website and complete the warranty form and mail to: Superior Plastic Products, Inc., 260 Jalyn Drive, New Holland, PA 17557*



WARNING: This product can expose you to chemicals including Quartz (crystalline silica), which is known to the State of California to cause cancer, and Hexavalent Chromium, which is known to the State of California to cause birth defects or other reproductive harm. For more information go to www.P65Warnings.ca.gov.

Measure the height of the existing Posts to be covered.

On a Non-Abrasive surface; carefully cut the Wrap Panels to the correct lengths.

! Cutting Tip

Be sure to use a **fine-tooth blade approved for cutting PVC** and rest panels on a piece of **non-abrasive material** to protect from scratches.

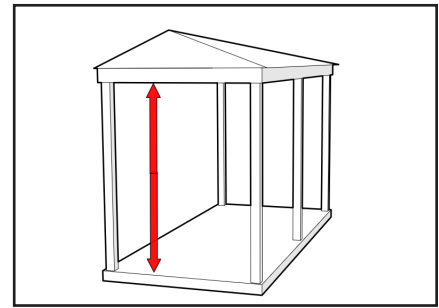
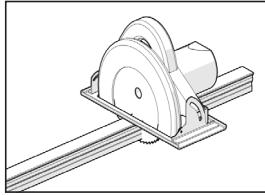

Snap together Panels in pairs then finalize the connection around the post by connecting the pairs.

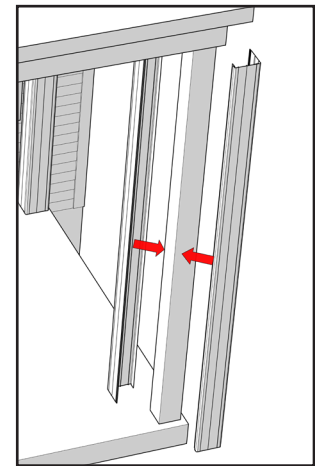
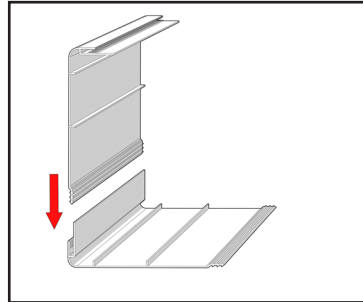

When snapping both pairs around the Post; ensure the Panels are square before finalizing the connection.

If necessary use blocks to expand the sides out to the proper widths at the Top, and Bottom. If you want to prepare for a future railing installation; a 12" block or shim should be placed 32" to 44" from the bottom of the Column; for extra support.

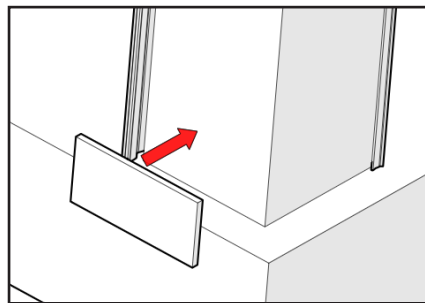

If utilizing Trim; connect the pieces around the Top and Bottom of the Post.

Use four Screws placed on all sides at both top and bottom; just below the edge of the Trim in order to hold them in place.

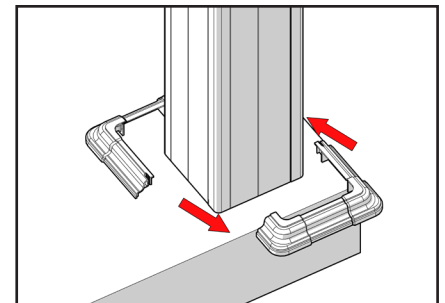

If Trim is not being used; screws can still be placed at the upper and lower areas of the Wrap Panels to help resist any twisting that might occur with a pressure treated Post.

When using Modular Trim, pieces can be cut down to fit other sizes of Post Wrap.

